

VANDERSTEEN

Congratulations on your purchase of the Vandersteen Model 2Ce Signature II. With proper care your new speaker system will provide many years of trouble free, high quality musical enjoyment.

We recommend that you read this entire manual prior to connecting or using your Model 2Ce Signature Loudspeakers.

Vandersteen Audio

The Vandersteen Audio Model 2Ce Signature II is a floor-standing, dynamic loudspeaker developed and refined by twenty years of advanced research into loudspeaker design. The engineering, construction and materials of the Model 2Ce Signature II far exceed conventional industry standards and have resulted in a level of musical performance unmatched by larger and more costly designs.

The Model 2Ce Signature II is a worthy addition to any high quality music system. The innovative first order crossover supports bi-wiring or vertical bi-amplification. Superb dynamic and transient response guarantees superior performance from records, tapes, CDs and video sources. Custom engineered drivers, built exclusively for Vandersteen Audio, are mounted in special baffles designed to maximize each drivers accuracy and musicality. An aesthetically pleasing appearance, incorporating an acoustically transparent grille and an audibly vented top, allows the Model 2Ce Signature II to compliment the décor of your home.

The Vandersteen Audio Model 2Ce Signature II is designed and built in the United States of America.

MODEL 2Ce SIGNATURE II LOUDSPEAKER OPERATIONS MANUAL

CONTENTS

CONNECTIONS	2	CONTOUR CONTROLS	8
OVERVIEW	2	SET-UP HINTS	9
MONO-WIRE	2	ASSOCIATED EQUIP.	9
ENHANCED MONO-WIRE	3	AMPLIFIER REQUIREMENTS	9
BI-WIRE	3	COMPONENTS	9
VERTICAL BI-AMP	3	CABLES	9
BI-WIRE THEORY	4	SPEAKER CARE	10
BI-AMP THEORY	4	MAINTENANCE	10
SPEAKER SETUP	5	SERVICE	10
SPEAKER PLACEMENT	5	PACKING INSTRUCTIONS	10
ODD DIMENSIONS	5	SPEAKER INFO.	11
THIRD DIMENSIONS	7	REFERENCE INFORMATION	11
ACOUSTIC CENTER	7	2Ce SIGNATURE SPECIFICATIONS	11
TOE-IN	7	WARRANTY	12
ACOUSTIC TREATMENTS	7		
LISTENING HEIGHT	8		

CONNECTIONS

As part of the upgrades and improvements that elevate the performance of the 2Ce Signature II above the Model 2Ce, the banana jack inputs are replaced with a four terminal barrier strip. This requires different cable terminations and connection methods than those detailed in the 2Ce manual.

Please follow the appropriate instructions below when connecting your 2Ce Signature II Loudspeakers.

With all the connection methods, the input screws should be snug, but should not be over

With all the connection methods, bare wires should never come into contact with the aluminum plate while the amplifier is on. Amplifier damage could result.

Carefully verify cable polarity at both speaker and amplifier before using the bi-wire or vertical bi-amp connection methods.

TRUE BI-WIRE CONNECTIONS

True bi-wiring is recommended for all systems using a single stereo amplifier or two mono amplifiers. Four identical runs of equal length cable are required. (Two per speaker).

1. Crimp and solder spade lugs to the speaker ends of the cables being used to connect the 2Ce Signatures II.
2. Choose one of the cables as high-frequency cable. Connect this cable to the two terminals on the right carefully observing proper polarity.
3. Connect the remaining cable to the two left terminals carefully observing proper polarity.
4. Connect both cables in proper polarity to the same set of outputs on your amplifier. If possible, use only one spade lug to connect both cables to each terminal on the amplifier as shown in the amplifier connection.

**True
Bi - Wire**

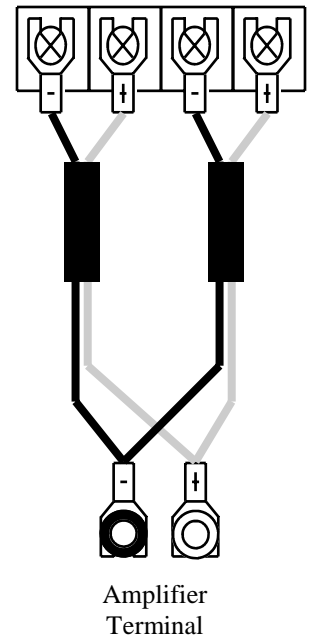

INTERNAL BI-WIRE CONNECTIONS

If your domestic situation dictates the use of a single cable per speaker, you should use a multiple-conductor single-sheath cable to internally bi-wire the speakers. Some of these cables use different types of wire for the upper and lower ranges of the speaker and may affect the blend between the woofer and midrange drivers. They should only be used after you audition them in your system and verify that they do not affect the woofer to midrange blending and that you like their sonic characteristics.

1. Crimp and solder spade lugs to the speaker ends of the cable from the amplifier.
2. Connect one positive and one negative wire to the high-frequency terminals on the right carefully observing proper polarity.
3. Connect the remaining positive and negative wires to the low-frequency terminals on the left carefully observing proper polarity.
4. Connect the wires in proper polarity to the same set of outputs on your amplifier. If possible, use only one spade lug to connect both positive wires and one spade lug to connect both negative wires to the amplifier as shown in the diagram.

**Internal
Bi - Wire**

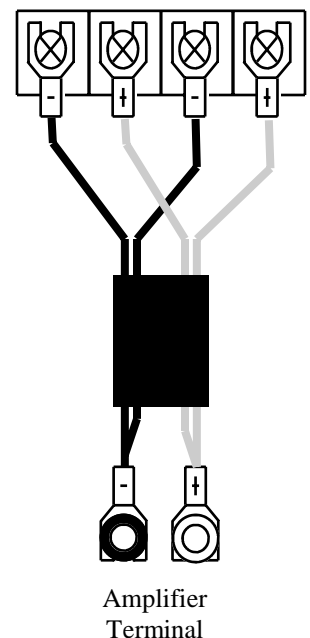

ENHANCED MONO-WIRE CONNECTION

Mono-wiring should only be used with the 2Ce Signature II as a temporary connection method. The speakers should be bi-wired as soon as possible.

1. Cut two sections of insulated wire about 2½ inches long to make two jumper wires. Crimp and solder spade lugs to all four ends of the two jumper wires.
2. Connect one end of a jumper wire under the high - frequency negative terminal screw and one end of the other jumper wire under the high-frequency positive terminal screw.
3. Crimp and solder spade lugs to the speaker ends of the cable from the amplifier.
4. Connect the negative side of the speaker cable and the jumper cable from the high-frequency negative terminal screw under the low-frequency negative terminal screw.
5. Connect the positive side of the speaker cable and the jumper cable from the high-frequency positive terminal screw under the low-frequency positive terminal screw.
6. Connect the speaker cables to your amplifier. Verify proper polarity.

VERTICAL BI - AMP CONNECTIONS

Caution: Some solid state amplifiers are not stable driving a capacitive load. Listen for high frequency oscillation (brightness) and higher amplifier operating temperature.

We only recommend bi-amplification when every component in the system is the best available and there is no other path to improving the system, otherwise, you are better off investing in the best single amplifier within your budget rather than dividing your budget between two less expensive, inferior sounding amplifiers.

Vertical Bi-amplification uses a stereo amplifier to drive each speaker. Four identical runs of equal length speaker cables are required (Two per speaker).

1. Connect two cables to each speaker as described in steps 1-3 of the true bi-wire section on the previous page.
2. Designate one stereo amplifier as the left channel amplifier and the other identical stereo amplifier as the right channel amplifier.
3. Connect the preamp's left channel output to both inputs of the left amplifier using two sets of preamplifier outputs and two cables or one cable and a high quality single female to dual male "Y" connector. Use the same method to connect the preamplifier's right channel output to both inputs of the right amplifier.
4. Connect the low-frequency cable from the left speaker to one channel of the left amplifier. Connect the high-frequency cable from the left speaker to the other channel of the same amplifier. Verify proper polarity.
5. Repeat step 4 for the right speaker and the right amplifier.

The performance of the Model 2Ce Signature is compromised by a mono-wire connection. For optimum performance you should bi-wire the speakers.

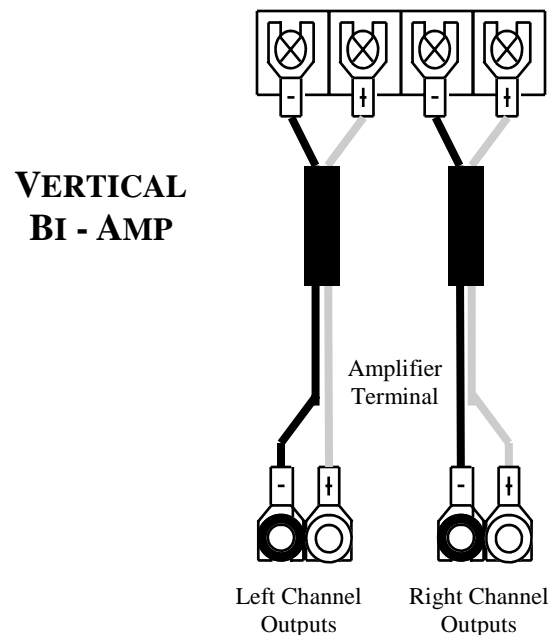
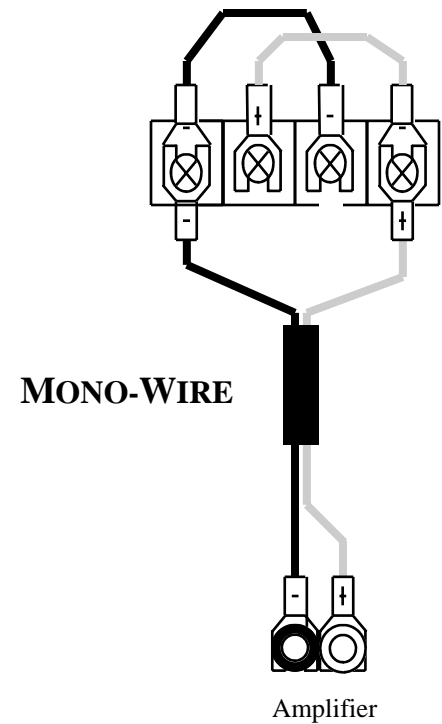

WE RECOMEND

- A. All speaker cables in bi-wired or bi-amped systems should be the same type and length. While certain different cables may work well together, identical cables on both inputs insures perfect blending.
- B. If your amplifier has “A” and “B” outputs, use the “A” outputs for both cables in bi-wired systems. The two sets of outputs may not be electrically identical.
- C. If your amplifier has multiple impedance taps, try the 4 ohm and 8 ohm taps to see which sounds better. (They will sound different). The 2Ce Signature II is an easy load so there is no danger of damaging your amplifier or the speakers by using either set of taps. In bi-wired and bi-amped systems, both cables must be connected to the same rated taps on the amplifier.

BI-WIRING THEORY AND PRACTICE

The effects of bi-wiring are not subtle. The improvements are large enough that a bi-wire set of moderately priced cable will usually sound better than a single run of far more expensive cable.

All the cables in a bi-wire set must be the same. There is often great temptation to use a wire known for good bass response on the woofer inputs and a different wire known for good treble response on the midrange/tweeter inputs. This will cause the different sonic characteristics of the two wires in the middle frequencies to interfere with the proper blending of the woofer and midrange driver through the 600Hz crossover point. The consistency of the sound will be severely affected as the different sounding woofer and midrange drivers conflict with each other in the frequency range where our ears are most sensitive to sonic anomalies. The disappointing result is a vague image, a lack of transparency through the midrange and lower treble and loss of detail and clarity.

Some of the benefits of bi-wiring seem to come from the physical separation of the high current bass and low current

midrange/tweeter wires. Cables that combine the wires in one sheath do not offer the full advantages of bi-wiring.

The cables should all be the same length. This is not due to the time that the signal takes to travel through a cable, but rather that two different lengths of the same cable will sound different. If the cables connecting one speaker are a different length than the cables connecting the other speaker, the resulting difference in sound between the two speakers will compromise the imaging and coherence of the system. If different lengths of cable are used for the bass and midrange/tweeter inputs of the speakers, the effects will be similar to those experienced when using two different cables as described above.

Since short runs of speaker cable sound better than long runs, consider placing your electronics between the speakers rather than off to one side. If for convenience or aesthetic considerations, the electronics must be located a considerable distance from the speakers, it is usually preferable to place the amplifier between the speakers and use long interconnect cables and short speaker wire.

BI-AMPLIFICATION THEORY AND PRACTICE

When you vertically bi-amplify with two identical amplifiers, almost every aspect of the Model 2Ce Signature II's performance is enhanced compared to bi-wiring with just one of the amplifiers. In most cases however, bi-wiring with a single, twice-as-expensive, better sounding amplifier will offer greater performance improvements for the same investment.

With the separate inputs for the midrange/tweeter and woofer on the 2Ce Signature II's, you may be tempted to bi-amplify the speakers using a powerful amplifier or an amplifier known for superb bass performance on the woofer input and a smaller amplifier or an amplifier renowned for middle and high frequency performance on the midrange/tweeter input. But rather than improving the sound of your system with the addition of a second amplifier, you will have taken a significant step backwards in coherence, accuracy and musical realism.

The reasons for this sonic penalty are simple. One of the strongest aspects of the Model 2Ce Signature's performance is the seamless transition between the drivers. Whether the music is in a range being reproduced by the woofer, by the midrange, or equally by both drivers, there is no audible change to the characteristics of the instruments or voices.

But, when the midrange driver is being driven by a different amplifier than the woofer, (and in these cases by amplifiers not chosen for the similarity in their sounds, but rather for the difference in their sounds), the blending between the drivers is compromised and the sonic consistency of the speaker is inhibited.

Even if the levels of the two amplifiers are matched for one volume level, the amplifiers will still exhibit different dynamic characteristics, different imaging characteristics, different degrees of detail and instrument texture and different tonal balances. With the crossover between the woofer and midrange occurring in a range where the ear is very sensitive to any sonic changes, these differences will create considerable sonic confusion through the important midrange.

The only way to properly bi-amplify the Model 2Ce Signature II is passively with two identical amplifiers in a vertical configuration. (one stereo amplifier per channel) An electronic crossover cannot be used since the crossover in the Model 2Ce Signature II is not bypassed. The result would be two crossovers in series creating severe phase shift. The use of two different amplifiers or an electronic crossover will negatively affect the sound of the speakers and reduce their overall performance level.

SETTING-UP THE SPEAKERS

The Model 2Ce Signature II requires a break-in period of at least 100 hours at a moderate volume level before its performance stabilizes. Higher volume levels will not shorten this break in period.

Vandersteen speakers will produce excellent, satisfying sound placed almost anywhere in a room. With all the possible variables in room layout, there are no magical formulas for determining the best speaker placement in every room. Since every room is different, we recommend that you try the speakers in every domestically acceptable location to find where they sound the best in your particular listening environment. The following sections contain suggestions that may be helpful in your placement experiments.

SPEAKER PLACEMENT

The 2Ce Signature II is not magnetically shielded and should be positioned at least 10 inches away from a direct view television set.

Problems can arise when you attempt to place a given loudspeaker, either front radiating or dipole, into a typical domestic environment. These problems are a function of the physical dimensions of the room. The room's dimensions dictate where in the room a node or anti-node will occur. Frequency response dips and peaks caused by nodes and anti-nodes can easily overwhelm the inherent accuracy of a loudspeaker.

If, for example, you place a loudspeaker with excellent frequency response characteristics in the corner of a room, you will increase response below about 200Hz by 6dB. This particular condition is a worst case example but similar conditions apply throughout the room to some extent.

ODD DIMENSIONS PLACEMENT

Research on speaker placement has produced a method for reducing the nodes and anti-nodes in many rooms by positioning the loudspeakers on the odd dimensional intersections of the room. The odd dimensional intersections are the intersections of the imaginary lines you would draw if you divided the length of your room and the width of your room by odd numbers.

As an example, we will use a rectangular room measuring 14 feet wide by 18 feet long. We'll assume that you want to set the speakers on one of the short walls, although this method works equally well for long wall placement.

The first step is to take the length of the room, (18 feet in our example) convert it from feet to inches, ($18 \times 12 = 216$) and divide the result by odd numbers.

216 divided by 3 is 72 (all to the nearest inch)

216 divided by 5 is 43

216 divided by 7 is 31

216 divided by 9 is 24

216 divided by 11 is 20

216 divided by 13 is 17 (and so on; eventually

the lines pile on top of each other or the speaker runs into the wall.) The results are the distances in inches that the center of the speakers can be placed into the length of the room, away from the wall behind them, to minimize the nodes and anti-nodes.

Now we can graph these odd dimensions distances on a drawing of the room. We only need to graph them for the wall where we intend to place the speakers.

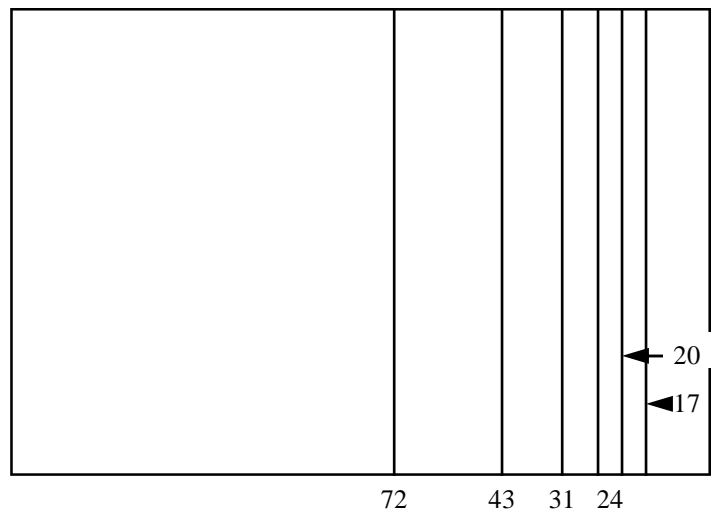

We use the same method to figure how far the centers of the speakers should be from the side walls. We take the width of the room, (14 feet) convert it from feet to inches,

(14 X 12 = 168) and divide the result by odd numbers.

- 168 divided by 3 is 56 (all to the nearest inch)
- 168 divided by 5 is 34
- 168 divided by 7 is 24
- 168 divided by 9 is 19
- 168 divided by 11 is 15

The results of these odd number divisions are the distances in inches that the center of each speaker can be placed into the width of the room, away from the side wall, to minimize nodes and anti-nodes.

Now we can graph these odd dimensions distances on a drawing of the room.

	15
	24
	34
	56
	56
	34
	24
	15

By overlaying the width and length graphs, we can see the intersection points of the lines. These points represent where the centers of the speakers should be placed to minimize nodes and anti-nodes.

					15
					24
					34
					56
					56
					34
					24
					15
	72	43	31	24	

As you can see, we now have quite a few intersections to choose from in our example room. Some of the intersections in your room will probably be eliminated by aesthetic or room function considerations, so you probably will not have as many.

As you try different placements for your speakers, always place both speakers on the same length line. For example, both speakers would be placed on the 24 inch line. The speakers can be placed on different width lines, for example one on the 34 Inch line and the other on the 56 inch line.

Placing the speakers on different rather than matching width lines will require that the listening position be offset to center it between the speakers. Often, the bass response of the system will be slightly more linear with the speakers placed on different width lines, (asymmetrical placement) while the imaging will often be better with the speakers placed on matching width lines (symmetrical placement).

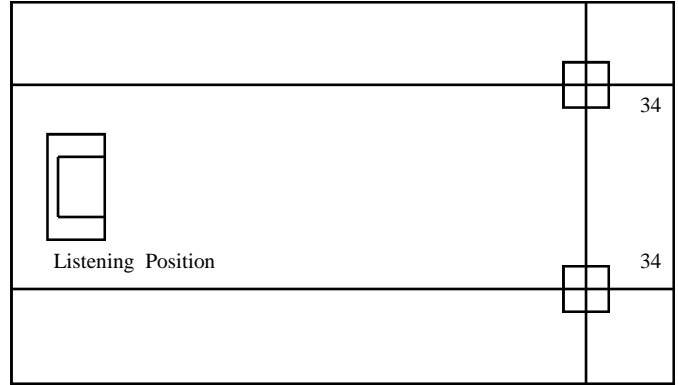

Symmetrical Placement

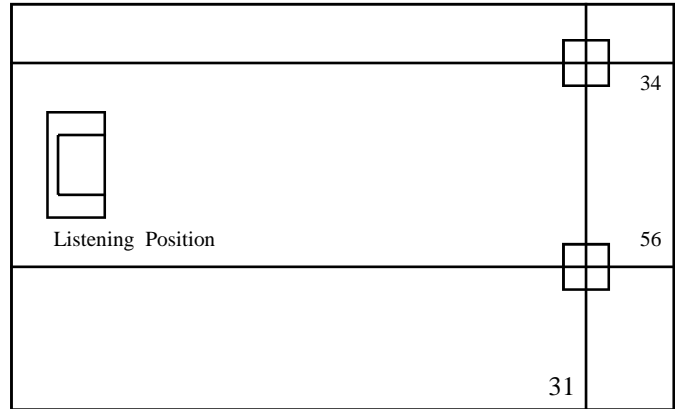

Asymmetrical Placement

After listening to the speakers centered on the charted intersections, you should listen with the speakers a couple of inches away from the intersection points in each direction. In some cases, the speakers will sound better slightly off the intersections due to the particular characteristics of your room or a slight error in your original room measurements. Both speakers should be moved the same amount forward or backward when fine-tuning placement.

Several factors influence how speakers interface with a room other than the room's basic dimensions so it is possible that none of the placement options on the wall you initially place the speakers on will sound quite right. The sound may have too much or too little bass or be too forward or too withdrawn. If you are unable to achieve satisfactory sound with the speakers placed on one wall, try placing the speakers on another wall of the room. Even in a rectangular room, the speakers will interface differently with the room depending upon which of the four walls they are placed. In some rooms the speakers will sound

best placed on a short wall while in other rooms the speakers will work better on a long wall.

THIRD DIMENSIONS PLACEMENT

A placement method that provides some unique effects is to place each speaker on the thirds of the room measurements and the listening position on the third of the length. The speakers are placed one third the length of the room from the wall behind them and one third the width of the room from the walls along side them. The listening position is then placed one third the length of the room from the wall behind it.

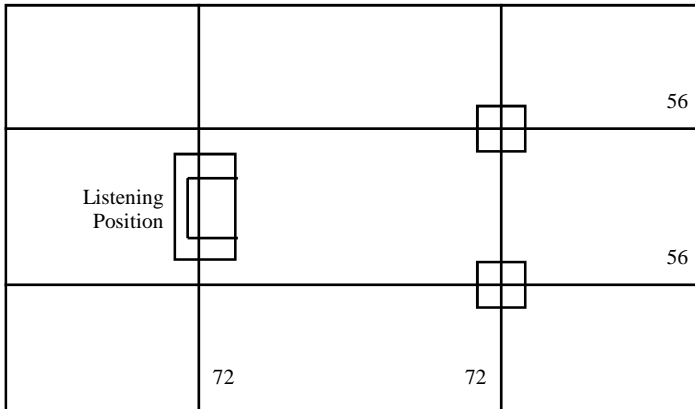

In our 14 by 18 foot example room, the thirds are 72 inches in the long dimension and 56 inches in the short dimension. The intersections of these measurements are used for third dimensions placement. In addition, the listening position is placed 72 inches from the rear wall of the room.

Both speakers should be tried up to two inches ahead and behind the intersections to determine if this improves the sound. Both speakers should be moved the same amount forward or backward.

Third dimensions placement reduces the interaction of the speakers with the room to an absolute minimum, but can create aesthetic or room function problems due to the speakers and listening position being so far out in the room. (The lower the odd number used to divide the room dimensions the lower the interaction between the speakers and the

ACOUSTICAL CENTER

The Model 2Ce Signature II acoustical center is the physical center of the loudspeaker. In a perfectly rectangular room with absolutely rigid walls and no doors or windows,

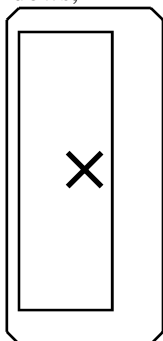

the acoustical center of the loudspeaker would be placed exactly at the point where the two dimensions intersect to realize the full benefits of odd dimensions or third dimensions placement. In a real room, the actual best placement may vary from the intersection by as much as two inches or so. Fine-tuning the placement by moving the speakers a couple of inches off the odd dimensions intersections takes these real world conditions into account.

You should not use any placements that

The same distance from the rear and side walls. The measurement from the center of the loudspeaker to the two walls should differ by at least two inches. If any of the odd dimension intersections are within two inches of the same distance from both the side and rear wall, you should not

SPEAKER TOE-IN

The degree of toe-in can affect the imaging and response characteristics of the speakers. In most rooms, the speakers will work well facing straight ahead or with a slightly toed-in. Speakers that are placed close to the side walls or in rooms with very reflective side walls may require additional toe-in to avoid a confused image and/or a forward midrange and treble.

If the speakers need an excessive amount of toe-in to image properly or achieve good center fill, there may be a problem with the set-up or connection of the speakers or some part of the system may not be functioning as intended. To determine why the speakers require excessive toe-in, check all your speaker wire connections for correct phase and verify that the electrical components in the system are connected and functioning properly.

ACOUSTIC TREATMENTS

If the speakers are close to the side walls and you hear a brightness in the midrange/treble or a problem with the imaging that toeing-in the speakers does not help, some sound absorbent material should be mounted on the side walls to control reflections.

to determine where the sound absorbent material should be placed, imagine that the walls are mirrors and mount the material on the walls where you would see the reflections of the speakers when you are sitting in your normal listening position. Before you actually mount anything on the side walls, experiment with folded natural-fiber blankets to verify that you will get the results you desire.

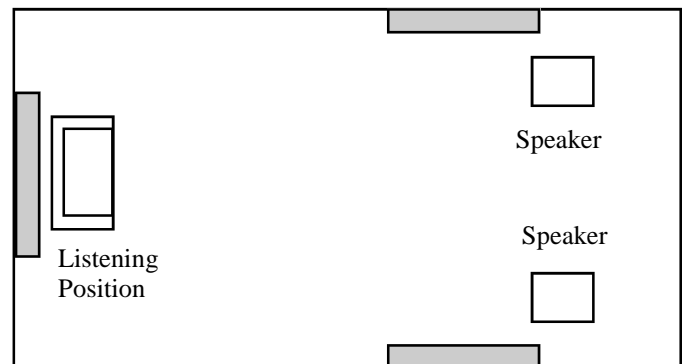

If your listening position is close to the wall behind you, mount some sound absorbent material, such as a hanging tapestry, directly behind your head. As with the material for the side walls, experiment with a folded natural-fiber blanket to verify the results before you acquire or mount the material.

Bass problems that cannot be corrected with placement adjustments may be helped by the addition of bass traps or other bass control devices. Follow the instructions of the bass control devices as to their proper set-up and placement to correct the problems you are experiencing.

LISTENING HEIGHT

The sound from a properly aligned loudspeaker reaches the listener with the audible frequencies correct in both time and phase. This lack of phase and time distortion contributes to a more accurate sound, but also makes listening at the proper height more important than with a nonaligned design. A characteristic of all properly aligned loudspeakers is that they are perfectly aligned at only one listening height. The further away your ears are from this perfect alignment height, the less accurate the speaker will be in the time and frequency domains.

The Model 2Ce Signature II is aligned for a 33 inch listening height when placed on a 3 inch high base. It has a vertical listening window extending about 3 inches above and below the alignment height where the sound of the speaker will still be quite good. Outside of the vertical listening window, the sound and performance of the speaker will be compromised.

If your ear height is above 33 inches at your normal listening position, the speakers can be leaned back according to the following instructions to raise the optimum listening window up to your ear height.

1. Measure the distance from the listening position to the speakers and the height of your ears when you are seated at the listening position. (Ear height is roughly equal to the height of the tip of your nose).
2. Find the values closest to your actual measurements on the chart at the right.
3. Follow the horizontal line across from your distance and the vertical line up from your ear height to the point where they intersect. The graph lines numbered from 0 to 3 1/2 indicate how many inches the top of the speaker should be behind the bottom of the speaker to center the six inch listening window at your listening height and distance.
4. Adjust the length of the base's front and rear spikes to lean the speakers backward the proper amount.
5. As an example of how to get the proper amount of lean:
 - a. Tie a nut to a piece of thread about four feet long.
 - b. Hang the thread and nut from the back of the speaker and measure the distance the nut is away from the bottom of the speaker as shown in the diagram. This measurement is the amount of speaker lean. (For clarity, the lean in the diagram has been exaggerated and the base is not shown).

Distance From Speakers In Feet

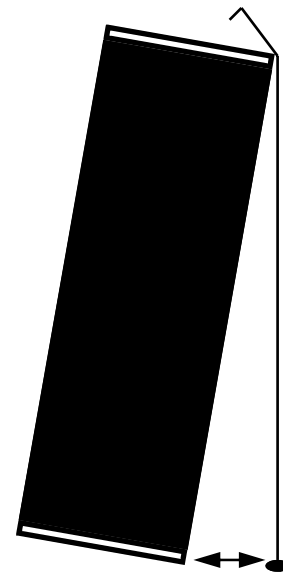
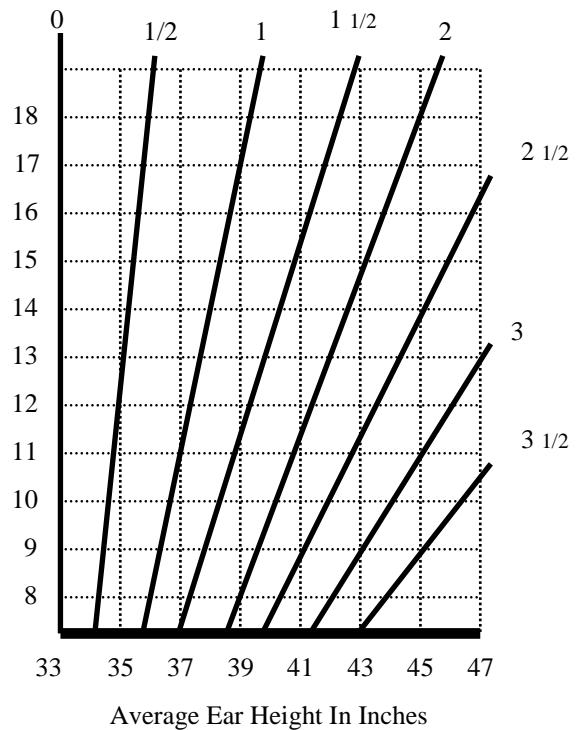

THE CONTOUR CONTROLS

Two contour controls are located on the aluminum dress plate at the rear of the Model 2Ce Signature. The upper control adjusts the tweeter level and the lower control adjusts the midrange level.

The contour controls are used to compensate for a bright or dull room that could not be corrected with speaker placement, acoustical treatments or other passive means. The controls are limited in their effects and even at maximum rotation they will not take the response of the speaker out of a plus or minus 3dB envelope. Changing the contour

controls will not affect the detail, imaging or phase performance of the speakers due to their unique incorporation into the crossover circuitry.

When using the controls, we recommend that you start with small adjustments and only change the midrange controls or the tweeter controls before listening for the effects of the change. By changing only one pair of controls, you will be able to determine the effects that each pair of controls have upon the sound of the speakers in your room.

HELPFUL SET-UP HINTS

- A. To try the speakers on different walls, set your equipment in the middle of the room so the speaker cables can reach each position.
- B. When you change the placement of the speakers, listen to several different pieces of music before judging the results.
- C. If you set the speakers on a wood floor, place a coin under each stand spike or use 3/8-16 thread carriage bolts in place of the spikes to prevent damage to the floor. Carriage bolts have rounded heads that will not put holes in the floor.
- D. Keep the spikes or carriage bolts on the bottom of the stands as short as possible while still accomplishing the proper vertical angle for your listening height and distance.
- E. When you have discovered the optimum speaker positioning in your room, mark it with tape so you can move the speakers to vacuum without losing your placement reference.
- F. If the bass is ill-defined in your room regardless of where you place the speakers, check your windows for loose panes of glass. Loose glass will vibrate and can seriously impair the low frequency detail of the system.
- G. Keep notes on the sound different placements you try. It is easy to get mixed-up and forget which placement sounded the best.
- H. Don't over-analyze sound of each placement. When the sound is right, it will be obvious.

ASSOCIATED EQUIPMENT

AMPLIFIER REQUIREMENTS

The Model 2Ce Signature II is designed for use with amplifiers rated at 40 to 160 watts per channel into 8 ohms. Amplifiers in this power range will provide ample power for realistic listening levels in most situations. Amplifiers with less than 40 watts may not be able to drive the Model 2Ce Signature to realistic listening levels without stress, while amplifiers with more than 160 watts must be used with caution due to the increased potential for speaker damage if they are misused or an accident occurs.

The Model 2Ce Signature II's are very revealing speakers and are easily capable of showing subtle sonic differences between amplifiers. They will perform well with a

COMPONENTS

To maximize the performance of your system, you should properly set-up your components according to the manufacture's instructions. Each component should be placed on a piece of furniture or in a stand that is stable and not prone to vibration or rocking. An isolation base or isolation feet may improve the sound of some electronics.

Allow sufficient air space around the electronics for needed air circulation. Excessive heat can both shorten the

CABLES

Our evaluations and tests have convinced us the interconnect and speaker cables should be considered an integral part of the music system. Each brand and model of cable has its own sonic characteristic and contributes to the overall presentation of the music as much as any active component. The Model 2Ce Signature easily passes the amount of information required to hear these differences between cables.

The testing also confirmed the importance of keeping speaker cables as short as possible. In repeated trials, short runs of moderate to inexpensive speaker cable consistently out performed long runs of the same cable as well as much

transistor, or hybrid amplifier, allowing each design to realize its full potential. The amplifier can be a quality receiver, integrated amplifier or separate amplifier. The stable impedance of the Model 2Ce Signature reduces load induced amplifier problems, expanding the possible amplifier choices.

The stability of the amplifier to be used should be considered, as it will affect the current capability and therefore, the dynamics and realism of the music. A stable transistor amplifier will be able to deliver twice the wattage into 4 ohm load as it does into an 8 ohm load. Amplifiers with this ability should perform well with the Model 2Ce Signature.

the life of electrical components and impair their performance.

Preamplifiers and CD players should be left on all the time. Amplifiers should be turned off when the system is not being used. Once broken in, modern amplifiers sound good after only 20 minutes of warm-up. Leaving the amplifier on all of the time exposes the speakers to possible damage from power line anomalies or electrical component failure while the system is unattended

more expensive cable. If your speakers must be placed a long distance from your electronics, we recommend that the amplifier be placed between the speakers and long interconnect cables be used between the amplifier and power amplifier so that short speaker cables can still be used. Currently, long interconnect cables seem to compromise the sound of a stereo system less than long speaker cables.

When you evaluate different interconnect or speaker cables, remember that the dielectric in most quality cables takes many hours to fully form. These cables will not reach their full potential until they have been used for several weeks.

SPEAKER CARE

MAINTENANCE

The appearance and performance of the Model 2Ce Signature II can be enhanced by observing a few precautions and performing some simple maintenance.

The input jacks on the Model 2Ce Signature II and the banana plugs should be cleaned periodically with alcohol or a solution made specifically for cleaning electrical contacts. A cotton swab with a small amount of cleaning solution on it can be used to clean inside the input jacks. Other connection points in the system should be cleaned as recommended by the equipment's manufacturer.

SERVICE

In the unlikely event that one of your speakers should require service, please follow these procedures.

1. Verify that the problem is with the speaker by switching the left and right speakers. If the problem follows the speaker, it is in the speaker. If the problem does not follow the speaker, it is in the system before the speaker.
2. Connect the tweeter/midrange input and bass inputs separately to determine which section of the speaker has the problem

PACKING INSTRUCTIONS

To prevent physical or cosmetic damage, the Model 2Ce Signature II should always be properly packed in its original box prior to transportation or shipment. Please follow these instructions when packing the Model 2Ce Signature II.

1. Turn the speaker upside-down on a carpeted surface and remove the base.
2. Pull the plastic bag down over the speaker.
3. Slide the inner liner over the speaker.
4. Fit one of the end trays into the end of the inner liner **with the open area of the end tray facing away from the speaker.**
5. Holding the flaps out, slide the outer box over the inner liner all the way to the floor.
6. Carefully turn the box right-side up.
7. Close the plastic bag and place the remaining end tray into the inner liner as was done in step 4.
8. Close the flaps on the outer box and seal with strong tape.

Speakers must be spaced away from the ends of the outer box. If both ends trays are not available, space the speaker away from the ends of the box with cardboard or a similar protective material.

The grille cloth on the Model 2Ce Signature II can be vacuumed using a brush attachment that will not snag the cloth. The top should be treated as a piece of fine furniture. The wood veneers are oiled at the factory and can be maintained with a light application of Pledge or a similar product.

Care must be taken that objects that could mar the finish are not placed on top of the speaker. The speaker should not be exposed to excessive direct sunlight which can damage the fit and finish of the veneer.

3. Contact Vandersteen Audio. Describe the problem and the steps you have taken to isolate the problem to the speaker. A return authorization form will be sent to you.
4. When you receive the return authorization form, return the damaged or defective loudspeaker to Vandersteen Audio packed in its original box. Pack the filled-out return authorization form in the box with the speaker.

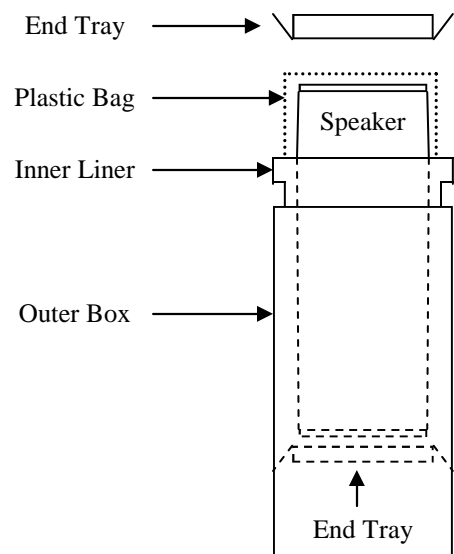

The open areas of the end trays must always face away from the speaker. The flat surfaces of the end trays must be against the speaker.

FOR FUTURE REFERENCE

Speaker Serial Numbers: _____

Purchase Date: _____

5 year warranty applied for: and received:

Dealer Name: _____

Dealer Address: _____

Dealer Phone: _____

Dealer Contact: _____

SPECIFICATIONS

Acoustic Coupler:	10" with critically damped long-fiber cone and heavy duty 1.5", four-layer voice coil with ventilated aluminum former. Range of operation: 28Hz to 35Hz.	Impedance:	7 ohms nominal. 4 ohms minimum.
Woofer:	8" with die-cast basket and curvilinear polycone. 1.5 inch, two-layer voice coil with ventilated aluminum former. 40oz focused-gap magnet structure. Range of operation: 35Hz to 600 Hz.	Efficiency:	86db with 2.83 volts of pink noise input at 1 meter on axis.
Midrange:	4.5" with die-cast basket, linear surround and curvilinear polycone. Ferrofluid voice coil cooling. Range of operation: 600Hz to 5kHz.	Response:	28Hz to 29kHz \pm 3db. 32Hz to 21Hz \pm 1.5db
Woofer:	1" critically damped metal alloy dome with ferrofluid voice coil cooling. Range of operation: 5kHz to 30kHz.	Recommended Amplification:	40 to 160 watts per channel into 8 ohms.
Crossover:	600Hz and 5kHz. First-order, 6dB per octave. Allows bi-wiring with a single amplifier or vertical bi-amplification with two identical amplifiers.	Video Applications:	Main or surround speakers. The Model 2Ce Signature is not magnetically shielded and should be positioned at least 10" away from the direct
		Physical:	39.75" high x 16" wide x 10.25" deep. 60 pounds net, 71 pounds gross each.

Specifications and design subject to change without notice due to continuing research and development.

VANDERSTEEN AUDIO

116 WEST FOURTH ST.
HANFORD, CA 93230
(559) 582-0324
www.vandersteen.com

LIMITED ONE YEAR WARRANTY

VANDERSTEEN AUDIO loudspeakers are warranted to the original purchaser to be free from defects in materials or workmanship, SUBJECT TO THE FOLLOWING CONDITIONS, for one (1) year from the date of purchase from an authorized VANDERSTEEN AUDIO dealer.

THIS WARRANTY IS SUBJECT TO THE FOLLOWING CONDITIONS AND LIMITATIONS:

This warranty is void and inapplicable if the loudspeaker have:

- A. Not been used in accordance with the instructions contained in the operation manual.
- B. Been subject to misuse or abuse; examples of which would be burned driver voice coils or burned crossover components.
- C. Been modified, repaired, or tampered with by anyone not specifically authorized to do so by Vandersteen Audio.
- D. Been subject to inputs in excess of the maximum rating, or inputs from an unstable or clipped amplifier.
- E. Suffered physical damage to the structure or components due to accident, neglect, or transportation.

IF A VANDERSTEEN AUDIO LOUDSPEAKER FAILS TO MEET THE ABOVE WARRANTY AND THE ABOVE CONDITIONS HAVE BEEN MET, THEN THE CUSTOMER'S SOLE REMEDY SHALL BE TO RETURN THE PRODUCT TO VANDERSTEEN AUDIO WHERE THE DEFECT WILL BE REPAIRED WITHOUT CHARGE FOR PARTS OR LABOR. THIS WARRANTY APPLIES ONLY TO PRODUCTS RETURNED TO VANDERSTEEN AUDIO IN HANFORD, CA USA.

(Returning the product to Vandersteen Audio from some countries other than the United States may involve considerable time and expense. The customer is responsible for all fees and duties and for providing instructions and all the paperwork required to return the product after it is serviced.)

The speaker must be packed in the original packing and returned to VANDERSTEEN AUDIO via insured freight by the customer at his or her own expense. A returned product must be accompanied by a Return Authorization Form, (available from VANDERSTEEN AUDIO upon request) which includes a written description of the defect and return shipping information.

ANY IMPLIED WARRANTIES RELATING TO THE ABOVE PRODUCT SHALL BE LIMITED TO THE DURATION OF THE ABOVE WARRANTY. THIS WARRANTY DOES NOT EXTEND TO ANY INCIDENTAL OR CONSEQUENTIAL COSTS OR DAMAGES TO PURCHASER.

Some states do not allow limitations on how long an implied warranty lasts, or an exclusion of incidental or consequential damages so the above limitations or exclusions may not apply. This warranty gives you specific legal rights, you may also have other rights in your state.

VANDERSTEEN AUDIO reserves the right to modify the design of any product without any obligation to previous purchasers and/or to change the prices or specifications without notice or obligation to anyone.

A PERSONAL NOTE

I have been doing volunteer work for several years with elderly people with severe hearing losses, and I have seen the frustration and anger that are brought on by these losses. We now know that many of these people developed their hearing problems because of exposure to high noise levels when younger.

Many home stereo systems, as well as audio/video, personal, and automobile sound systems are capable of volume levels potentially damaging to your hearing. Please use common sense, and listen to your music and movies at safe levels now so you will still have the ability to hear and enjoy them in the future.

Richard Vandersteen